

DRAWING MADE IN THIRD ANGLE PROJECTION

THIS DRAWING IS UNPUBLISHED. RELEASED FOR PUBLICATION .19
 © COPYRIGHT 19 BY AMP INCORPORATED. ALL INTERNATIONAL RIGHTS RESERVED.

MOD	LOC	DIST	P	F	ZONE	LTR	REVISIONS	DATE	APPD
4	BD	39				AE	REDRAWN, ADDED 1--4 PER NPR 3506	5-9-91	RW
						AF	ADDED 1--5 PER NPR 4680	04/02/93	RSK

WHEN ORDERING CONTACT ASSEMBLY ON TAPE, ORDER BY THE TAPE NUMBER PLUS THE PACKAGING CODE AS FOLLOWS:

1. FOR USE WITH AMP TAPETRONIC, PNEUMATIC TOOL-
 - A. 1000 PARTS TO A BOX ADD PACKAGING CODE: 1MBOX
2. FOR USE WITH 4/8 INDENT STRIPPER CRIMPER-
 - A. 1000 PARTS TO A REEL ADD PACKAGING CODE: 1MREEL
 - B. 5000 PARTS TO A REEL ADD PACKAGING CODE: 5MREEL

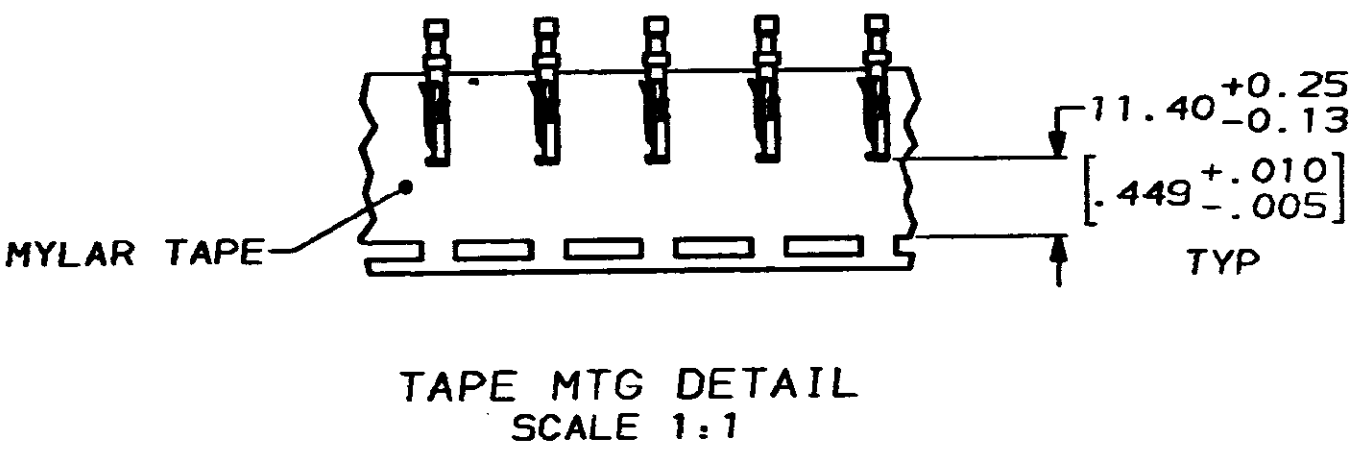
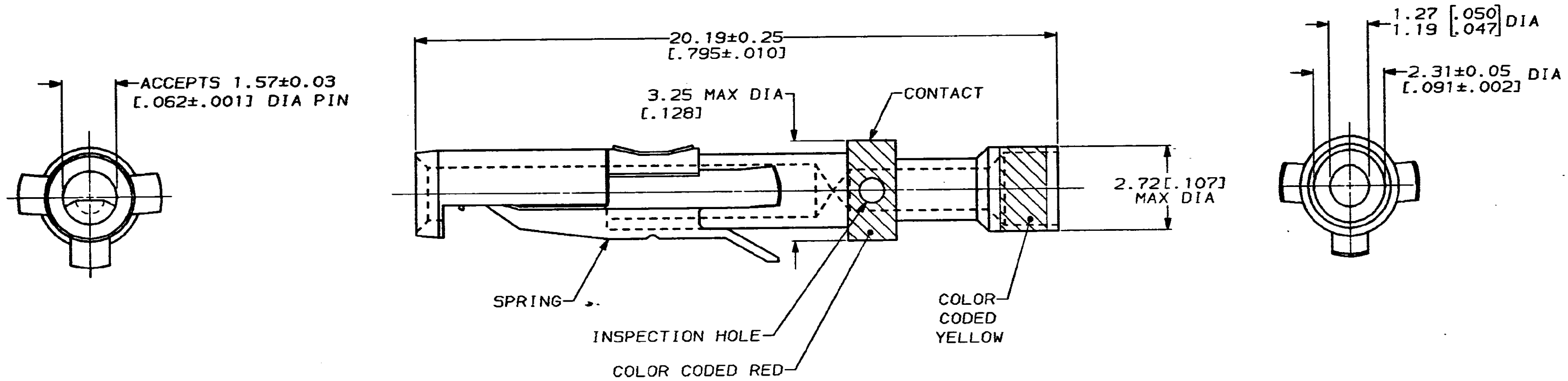

SMALL PACK	1-201328-5
KIT	1-201328-4
TAPE MTG SEE DETAIL	201328-9
BULK	201328-1
PACKAGING	PART NO

DO NOT SCALE PRINT. UNLESS SPECIFIED DIMENSIONS IN mm (INCHES) TOLERANCES ON: 2 PLC DEC ± - 3 PLC DEC ± - ANGLES ± -	DR 5-9-91 W.G. LENKER	AMP AMP Incorporated Harrisburg, PA 17105-3608		
	CHK 5-14-91 R. STONE			NAME
MATERIAL	APPD 5-14-91 R. WALTER	SOCKET CONTACT ASSEMBLY, TYPE II		
CONTACT: BRASS SPRING: STAINLESS STEEL	APPD -			
FINISH	PRODUCT SPEC	SIZE	CAGE CODE	DRAWING NO
CONTACT: $0.76 \mu\text{m}$ [$.000030$] MIN GOLD OVER $1.27 \mu\text{m}$ [$.000050$] MIN NICKEL	APPLICATION SPEC	C	00779	201328
	WEIGHT	SCALE	10:1	SHEET
				1 OF 1

CUSTOMER DRAWING